

# ENCO-METER

## EXTENDIBLE CABLE MEASUREMENT SYSTEM

ENCO-METER systems allow for a simple, fast and economic way, the adaptation of rotating sensor devices (encoders, and potentiometers etc.) of linear distance measurements of up to 10 metres for machines with slow movement, without any sharp acceleration and with an average number of maneuvers. They consist of a stainless steel micro-cable that has to be connected to the machine's mobile element at its free end. Inside the unit, the other end of the cable is wound on to a precision drum with a leaf spring to maintain it under constant tension. The drum shaft can drive any type of rotating sensor.



### Output devices

On request, we can supply the ENCO-METER already coupled to an electronic output device that could be an incremental or absolute encoder or a potentiometer. If it is required to obtain a determined resolution "r" (mm per pulse) in the case of using an absolute or incremental encoder, the number of encoder pulses will be:

$$n = \frac{D}{r} \quad (D \text{ is ENCO-METER travel in mm})$$

Using a potentiometer, an output "r" ratio (in  $\Omega$  per mm) is obtained in accordance with:

$$r = \frac{R}{D \times n} \quad (R \text{ is the rated resistance and } n \text{ is the maximum number of turns})$$

As standard, we have potentiometers of  $R=10K\Omega$  and  $n=10$  turns available in stock. It must be taken into consideration that the mechanical travel of the potentiometer may limit the ENCO-METER measurement range.

### Installation

ENCO-METER units are secured to a flat machine surface by means of three or four M14 screws. Any installation position is possible. The cable must be correctly

aligned ( $\alpha < 2^\circ$ ) and under no circumstances must it exceed the measurement range.

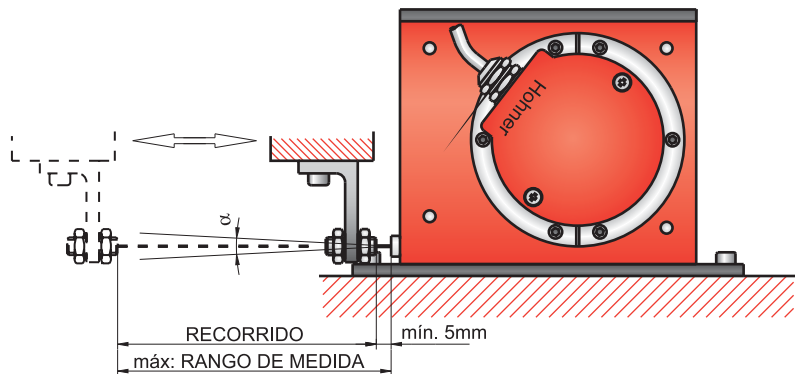

## TECHNICAL SPECIFICATIONS

Model	EM4	EM8	EM10
Reference	90.1404	90.1808	90.1810
Travel	200 mm $\pm$ 0,06 / per turn	250 mm $\pm$ 0,06 / per turn	300 mm $\pm$ 0,06 / per turn
Cable <sup>(1)</sup>	$\varnothing$ 0,61 AISI316 stainless steel (structure 19 x 7 + 0)		
Measurement range, up to (mm)	4000	8000	10000
Maximum cable extension (mm)	4010	8010	10010
Minimum cable static tension	3 N	6 N	6 N
Maximum cable static tension	8,9 N	13N	13 N
Maximum extension acceleration	35 m/s <sup>2</sup>	30 m/s <sup>2</sup>	25 m/s <sup>2</sup>
Maximum recovery acceleration <sup>(2)</sup>	10 m/s <sup>2</sup>	12 m/s <sup>2</sup>	12 m/s <sup>2</sup>
Maximum speed	1 m/s	0,75 m/s	0,75 m/s
Protection against dust and splashes	IP51 according to DIN 40050		

(1) Other types of cables are possible on special order

(2) We can supply EM4s with double drive torque, permitting the recovery acceleration to be doubled.

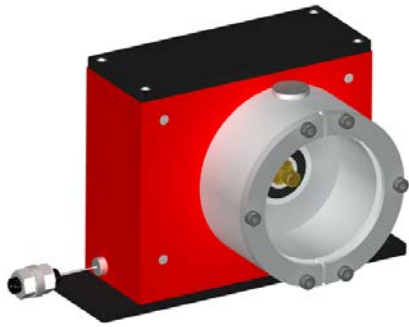

**EM4**

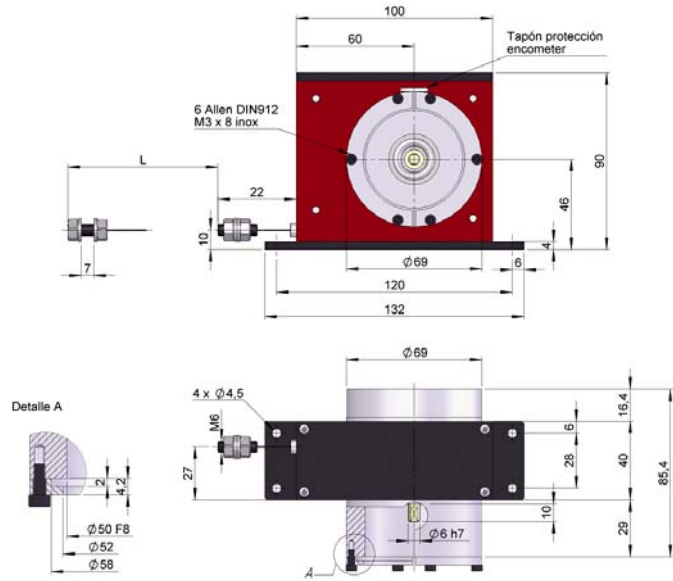

**EM8**

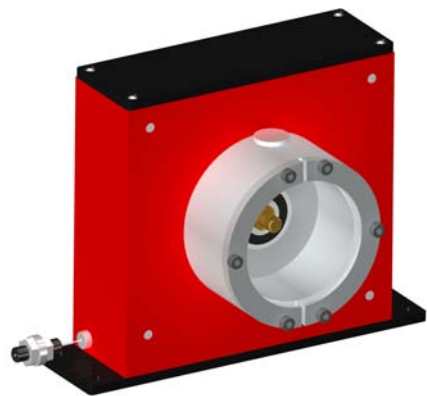
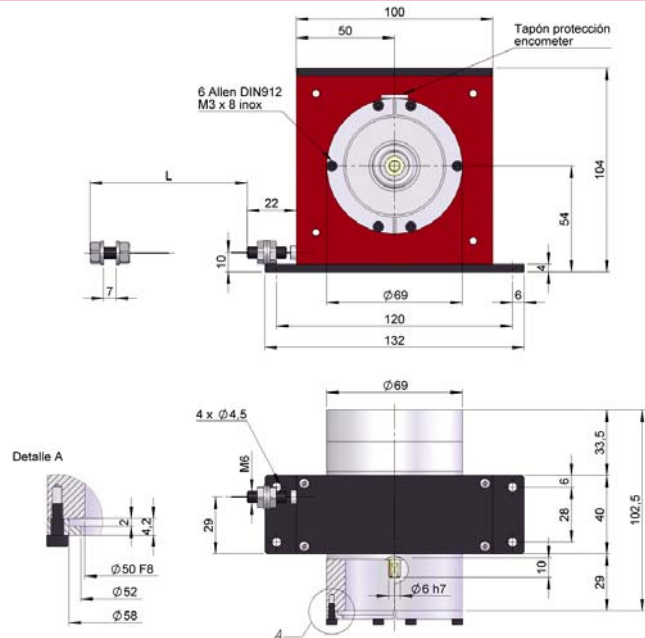

**EM10**

