

QR series



QR40-120HB-IK

Absolute rotary encoder (contactless)

Output
4 - 20 mA

Supply voltage
10 - 30V dc

Measuring range
120° (out of 360°)



General specifications v20121009

Housing	Quadro40: PBT black								
Dimensions	40x40x22 mm								
Mounting	2x stainless M4x25 mm screws								
Ingress Protection (IEC 60529)	IP66								
Weight	approx 75 gr (excl. cable)								
Shaft	Stainless steel Ø 6 mm								
Shaft type	D-form								
Shaft bearing	Polyamide (glass-filled), Radial force < 1Nm, Axial force < 8N (push & pull)								
Shaft length	8 mm								
Supply voltage	10 - 30V dc								
Polarity protection	Yes								
Current consumption	≤ 50 mA (excluding output signal)								
Operating temperature	-25 to 85°C								
Storage temperature	-25 to 85°C								
Measuring range	120° (out of 360°)								
Programmable center position	Yes (12 mA / 60°)								
Accuracy									
Resolution	12 bit f.s. (min step 0,088°)								
Max offset error	± 0,3° (after centering)								
Non linearity	< ± 1,4°								
Repeatability	0,12°								
Response time	< 10 ms								
Max speed	15 rpm								
Output signal	4 - 20 mA								
Short circuit protection	Yes (max 10 s)								
Output load resistor	Rload ≤ 50*Vs - 250 [Ω] (Eg: Vs = 24 V: Rload ≤ 950 Ω)								
Connection	Cable 2 m PVC/PVC Liyy, black Ø 4,6 mm, wires: 4x0,25 mm² Sensor colors (static usage)								
Wire coding	<table border="0"> <tr> <td>Brown</td> <td>+ Supply voltage</td> </tr> <tr> <td>Black</td> <td>Output</td> </tr> <tr> <td>Blue</td> <td>Gnd</td> </tr> <tr> <td>White</td> <td>Center input</td> </tr> </table>	Brown	+ Supply voltage	Black	Output	Blue	Gnd	White	Center input
Brown	+ Supply voltage								
Black	Output								
Blue	Gnd								
White	Center input								

QR40-120HB-IK

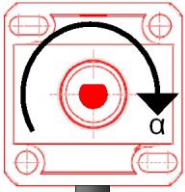

Rotation axis: CW

Transfer characteristic

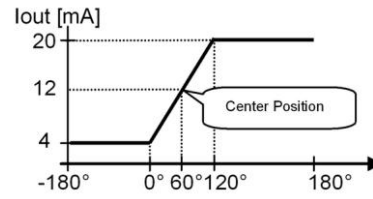

QR40-120HB-IK

Dimensions

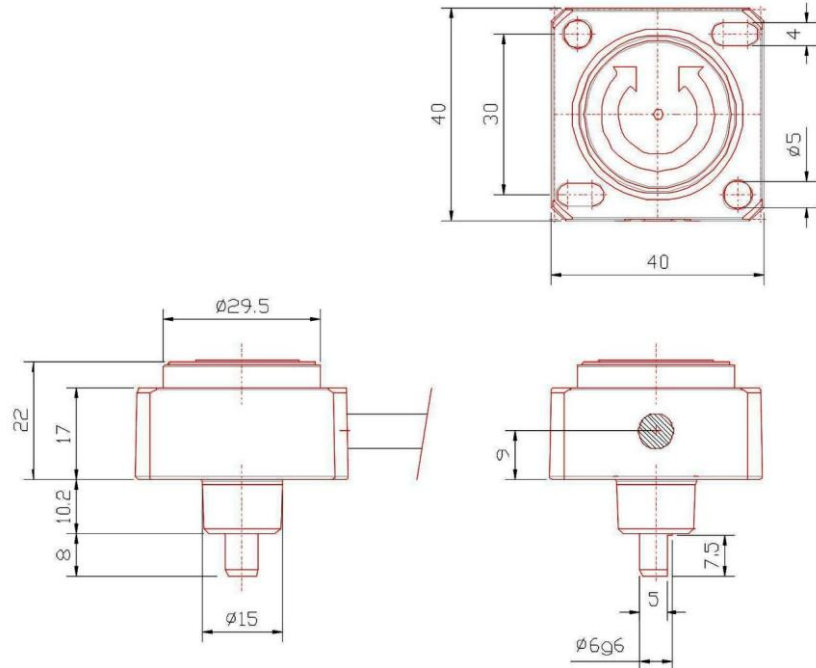

QR40-120HB-IK

Centering

Centering will store the current angle position as new center position into permanent memory. Centering can only be done in the 1st min. after power up, or within the 1st min. after centering. To perform a centering action the center input should be unconnected during power up, than connect the center input to ground for more than ½ sec. to activate centering. Centering is used to correct mechanical offsets.

QR40-120HB-IK