

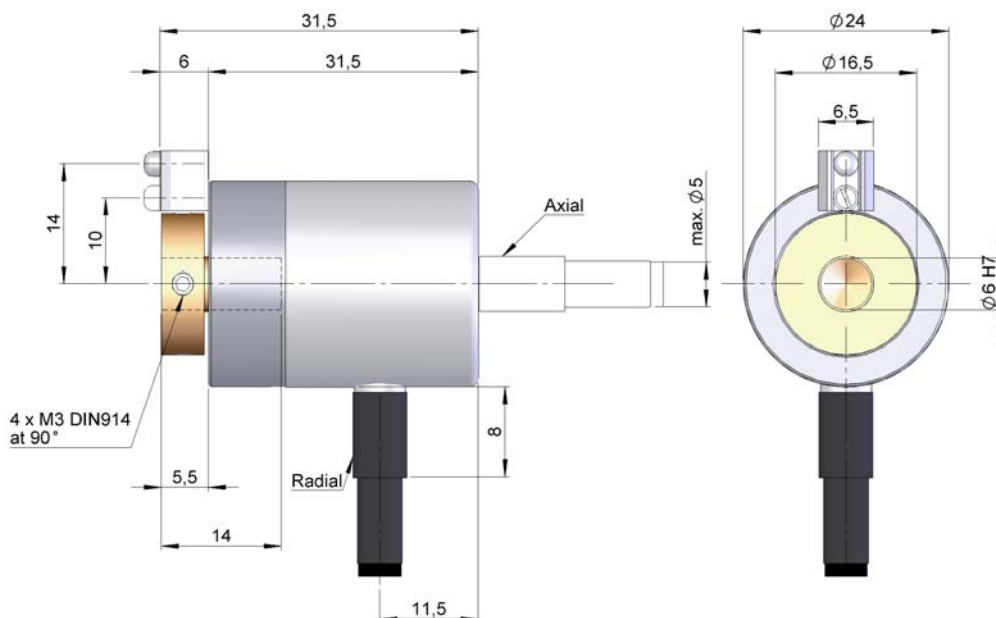

SERIE 28

BLIND HOLLOW SHAFT INCREMENTAL ENCODER FOR INDUSTRIAL APPLICATIONS

- Resolution up to 1024 pulses per turn
- External diameter 24 mm
- Blind hollow shaft 4 or 6 mm
- Protection class IP64 according DIN 40050
- Cable connection (any cable length available) or industrial connector.
- Antirotation system through pin torque support

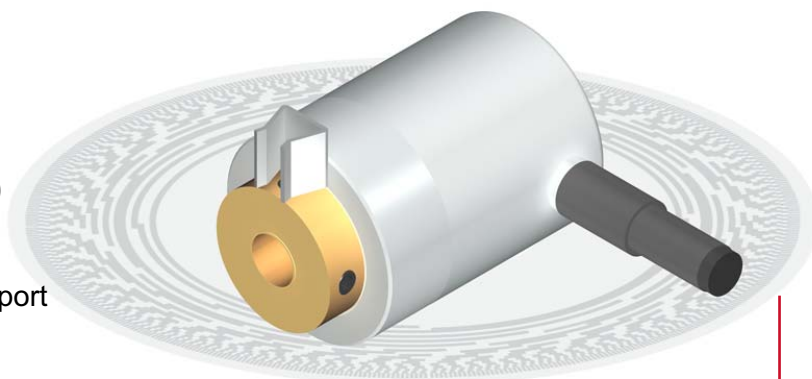

Previous mounting and installation of the encoder is recommended to read the section "TECHNICAL CONSIDERATIONS".

MECHANICAL SPECIFICATIONS

Housing	Aluminium.
Shaft	Brass / Treated aluminium..
Bearings	Ballraces.
Bearings lifetime	1x10 ¹⁰ rev.
Housing fixing	Pin torque support.
Blind hollow shaft diameter	4 or 6 mm.
Maximum number of revolutions permitted mechanically	6000 rpm.
Protection against dust and splashes according to DIN 40050	IP64.
Rotor inertia moment	1 gcm ² .
Starting torque at 20°C (68°F)	Máx 0,5 Ncm.
Maximum load permitted on axial shaft	Max. 10 N.
Maximum load permitted on radial shaft	Max. 10 N.
Weight aprox.	0,06 Kg.
Operating temperature range	-20°C to +80°C.
Vibration	100 m/s ² (10Hz...2000Hz).
Shock	1000 m/s ² (6ms).
Maximum pulses per turn	1024.
Axial or radial cable	Cable 2 metres (any cable length available on order).

ELECTRICAL SPECIFICATIONS

OUTPUT SIGNALS

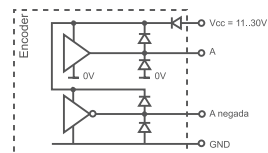
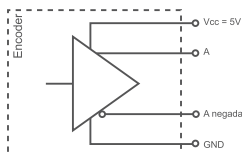

	RS422 (TTL compatible)	Push-Pull Differential
Power supply	5 V \pm 5%	11...30 V
Consumption	Typical: 70 mA Max: 150 mA	Typical: 45 mA Max: 150 mA
Max. load capability	\pm 20 mA	\pm 30 mA
Length of cable allowed	1200 m	100 m
"Low" signal level	$V_{OL} < 0,5 V$	$V_{OL} < 2,5 V$
"High" signal level	$V_{OH} > 2,5 V$	$V_{OH} > V_{CC} - 3 V$
Frequency	300 kHz	200 kHz
Shortcircuit protection	Yes	Yes
Protection against polarity inversion	No	Yes
Channel A leads (90° electric) channel B		

CONNECTION



	Cable 5x0,14	Cable 8x0,14
GND	White	White
Vcc	Brown	Brown
A	Green	Green
B	Yellow	Grey
A inverted		Yellow
B inverted		Pink
0 (reference)	Grey	Blue
0 inverted	Grey	Red

ORDERING CODE

SERIE	HOLLOW SHAFT	OUTPUT SIGNALS	CONNECTION	ELECTRONIC OUTPUT	PULSES NUMBER	SPECIAL CUSTOMER
28	● 1- Ø4 mm 2- Ø6 mm	● 3- A + B + 0 7- AA + BB + 00	● 1- Axial cable 2- Radial cable	● 1- Differential line driver. Push-Pull 11..30V 2- Standard RS422. 5V	●●●●●●●●	●●●●●●●●

ACCESSORIES

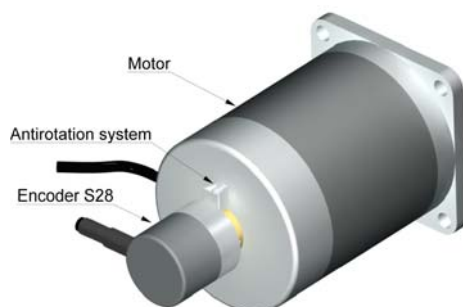

All the accessories available in the sections "SIGNAL CONDITIONERS" and "MOUNTING ACCESSORIES".